

Test: (F) Primary 4 - Term 2 (SA1) Science (MGS)

Points: 61 points

Name: \_\_\_\_\_

Score: \_\_\_\_\_

Date: \_\_\_\_\_

Signature: \_\_\_\_\_

Select multiple choice answers with a cross or tick:

Only select one answer

Can select multiple answers

**Question 1 of 48**

Primary 4 Science (Term 2) 2 pts

Booklet A (28 x 2 marks)

For each question from 1 to 28, four options are given. One of them is the correct answer.

Four pupils observed four animals, R, S, T and U and each made statements about the animals shown below.



R



S



T

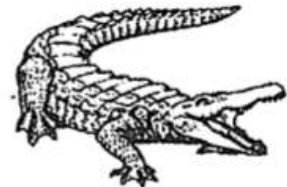

U

Ben R is a bird because it swims.

Meera S is a bird because it has feathers.

Rahman T is a fish because it breathes through its gills in water.

Seema U is an amphibian because it has scales on its body surface.

Whose statement(s) is/are incorrect?

- A) Ben only
- B) Meera only
- C) Meera, Rahman and Seema only
- D) Ben, Rahman and Seema only

Study the flowchart below.

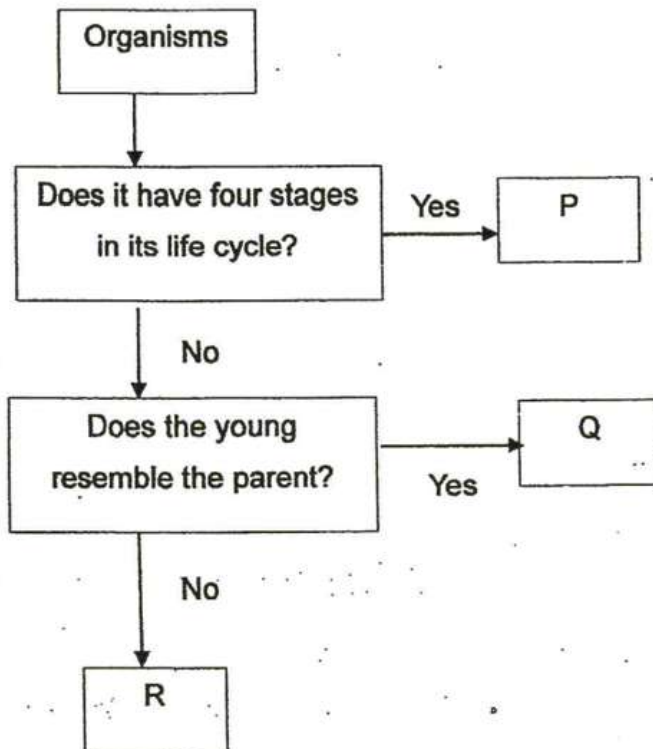

Which of the following could represent Organisms P, Q and R?

	P	Q	R
(1)	Frog	Mosquito	Grasshopper
(2)	Grasshopper	Frog	Butterfly
(3)	Mosquito	Grasshopper	Frog
(4)	Mosquito	Frog	Grasshopper

- A) 1
- B) 2
- C) 3
- D) 4

The diagram below shows some bracket fungi on a tree and some mould on an orange.

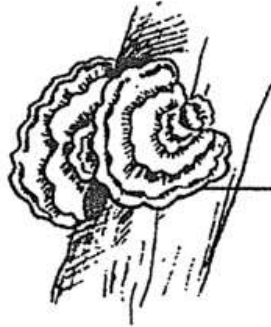

Bracket fungi on a tree



Mould on an orange

Which of the following statement(s) about these two organisms is/are correct?

- A Both do not bear flowers.
- B Both can be found in dry places only.
- C The bracket fungi belongs to a part of the tree.
- D The bracket fungi make their own food while the mould gets its food from the orange.

- 
- A) A only
  - B) A and C only
  - C) A and D only
  - D) B and D only

The organs below are supposed to be grouped according to the body systems that they belong to.

<b>Skeletal System</b>	<b>Digestive System</b>
Skull	Stomach
Ribcage	Heart
Lungs	Intestines

Which of the above are wrongly placed?

- 
- A) Skull and heart
  - B) lungs and heart
  - C) lungs and intestines
  - D) ribcage and stomach

Jeremy wanted to find out if plants respond to sunlight. He set up an experiment using similar plants as shown below and placed them in a garden for seven days.

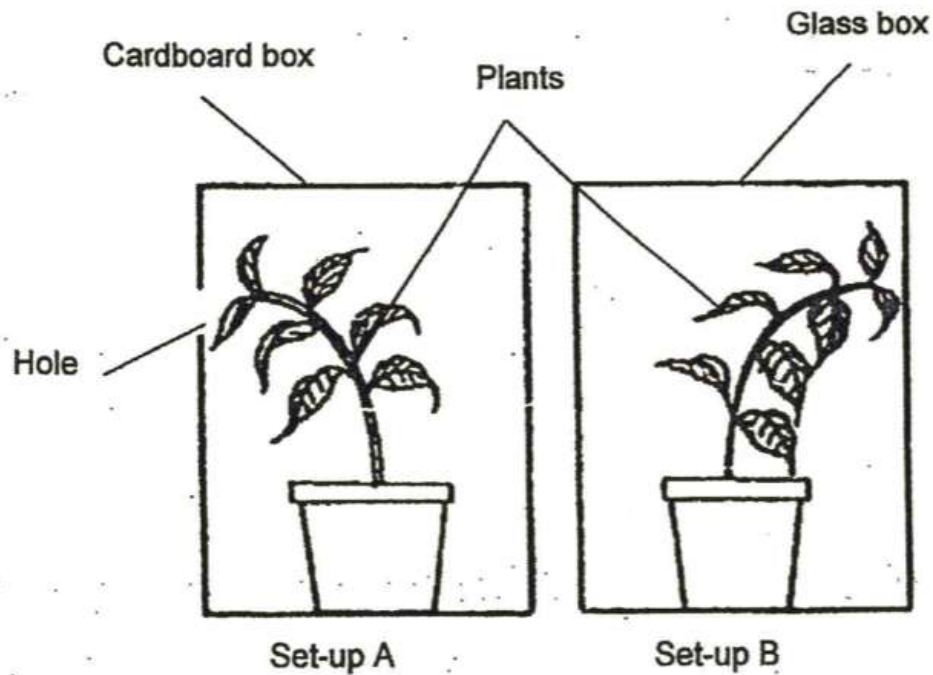

Why was the experiment not a fair test?

- A Only one of the boxes had a hole.
- B The plants had different number of leaves.
- C The boxes were made of different materials.
- D The duration of the experiment was too long.

- 
- A) A and B only
  - B) A and D only
  - C) B and C only
  - D) C and D only

John had four similar pots of seedlings from the same type of plant, labelled A, B, C and D. He gave each pot of seedlings the same amount of soil and fertilizers and gave different amount of water to each pot daily. He measured their average heights after nine days.

Pots	A	B	C	D
Amount of water given per day (ml)	25	35	45	50
Average height of seedlings(cm)	10	15	20	30

What could John conclude based on the results he had obtained?

- A) The plant need water to make food
- B) The plant need air, water and light to grow
- C) The plant grew faster when more water was given
- D) The plants reproduce faster when they received more water

Study the diagram below carefully.

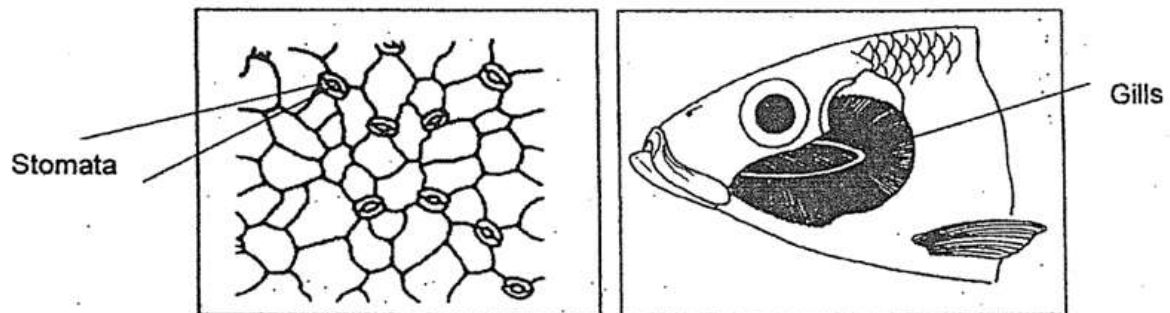

Which of the following statements is/are incorrect?

- A) The gills protect the fish from injuries.
- B) The stomata can help the plant to trap sunlight.
- C) Both the stomata and the gills allow the organisms to take in oxygen and give out carbon dioxide.

- A) A only
- B) C only
- C) A and B only
- D) B and C only

The diagram below shows how water and mineral salts are transported in a plant.



The function of the transport system in the plant is similar to the \_\_\_\_\_ system.

- 
- A) skeletal
  - B) muscular
  - C) circulatory
  - D) respiratory

The following diagram shows the life cycle of a mealworm beetle.

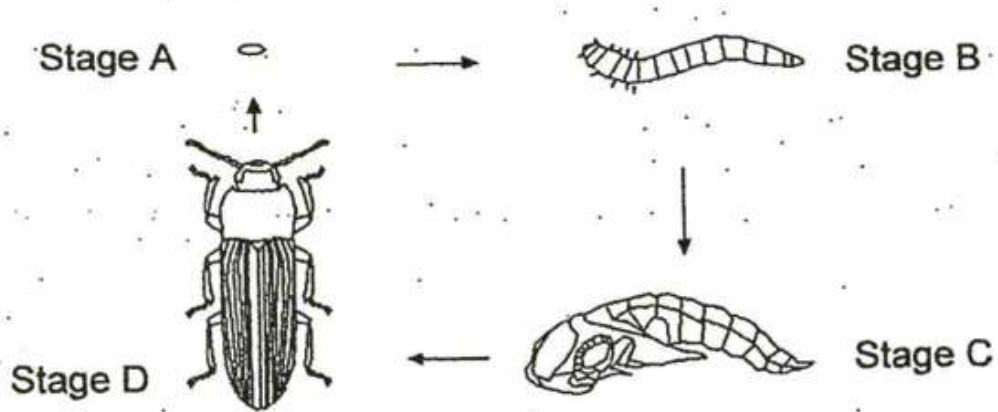

At which stage does moulting takes place?

- A) A
- B) B
- C) C
- D) D



Which one of the following shows the correct life cycle of a mosquito?

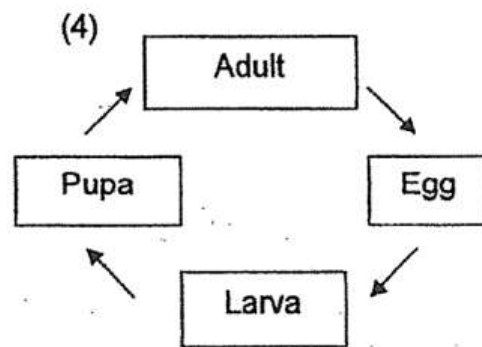
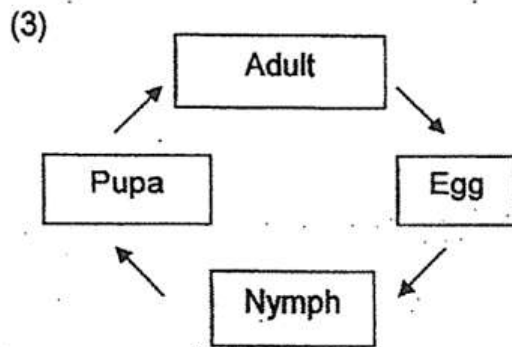
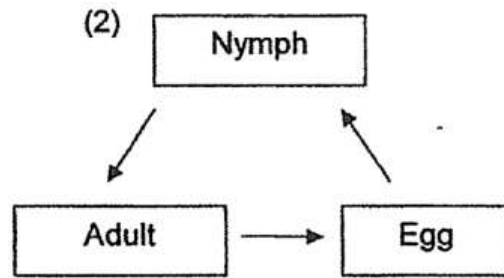
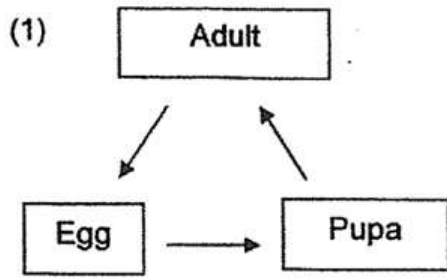

- A) 1
- B) 2
- C) 3
- D) 4

Question 11 of 48

Muthu planted a bean seed and then wrote a journal about the growth of his bean plant. However, he did not record the growth of his bean plant in the correct order.

- A The shoot appears
- B The root appears
- C The leaves grow
- D The flowers bloom
- E The fruits grow

Which one of the following shows the correct order?

- A) A -> C -> E -> D -> B
- B) B -> A -> C -> D -> E
- C) B -> C -> A -> D -> E
- D) C -> A -> B -> E -> D

The diagram below shows a plant with one of its part labelled X.

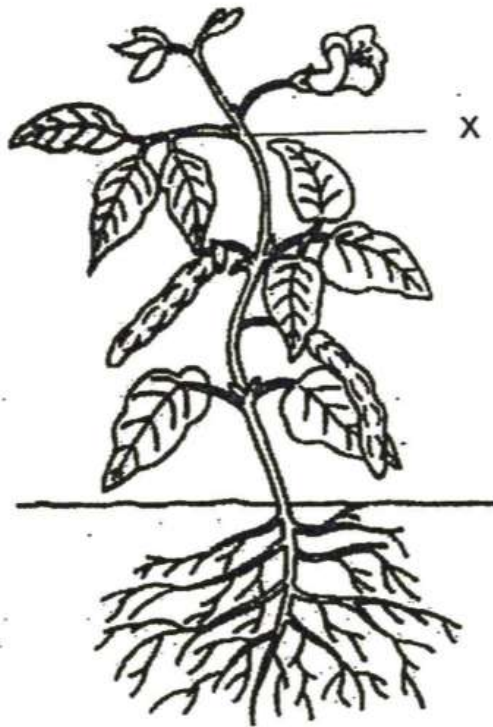

Which one of the following statements is false about the function of part labelled X?

- A) It holds the plant firmly to the ground
- B) It carries food to the other parts of the plant
- C) It holds the leaves up to reach for sunlight
- D) It carries water and mineral salts to other plant parts

The diagram below shows a seedling and an adult plant.

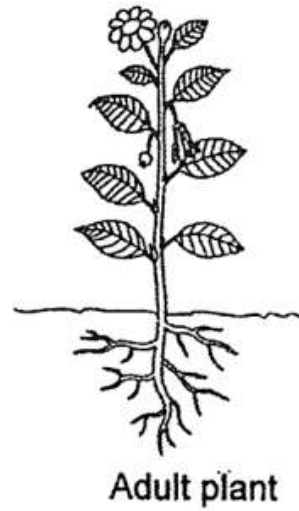
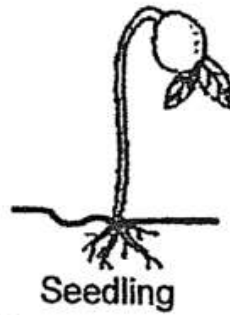

Which of the following are true for both the seedling and the adult plant?

- A Have strong stems.
- B Make their own food.
- C Bear fruits to reproduce.
- D Absorb water and mineral salts through their roots.

- 
- A) A and C only
  - B) B and D only
  - C) A, B and D only
  - D) B, C and D only

Wei Ling collected some information on three different organisms P, Q and R and recorded it in a table as shown below.

Characteristics	Organisms		
	P	Q	R
Its young moults	Yes	Yes	Yes
Has 3 stages in its life cycle	Yes	Yes	No
Spends part of its life cycle in water	Yes	No	No

Based on the information given, which of the following statements are correct?

- A P and Q can fly.
- B P can be a frog.
- C Q can be cockroach.
- D The young of R does not look like its adult.

- 
- A) A and D only
  - B) A and C only
  - C) C and D only
  - D) B, C and D only

Mrs Sim wants to sew a set of curtains to reduce the glare from the sun during the daytime. The graph below shows the amount of light that can pass through each type of material, A, B, C and D.

Amount of light that  
can pass through

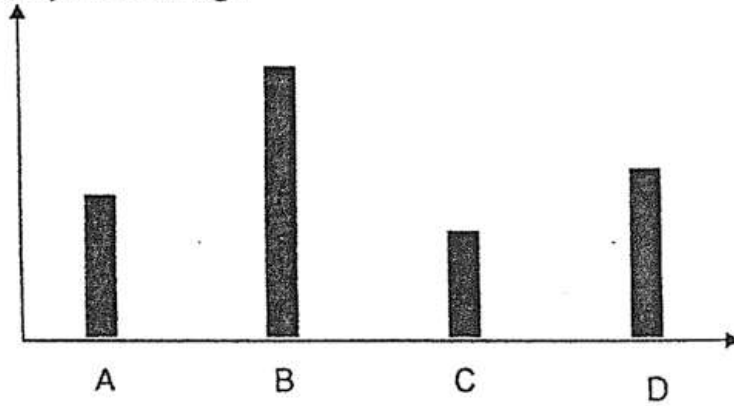

Type of material

Which one of the following material should Mrs Sim choose to make the window curtains?

- 
- A) A
  - B) B
  - C) C
  - D) D

Item R has the following characteristics.

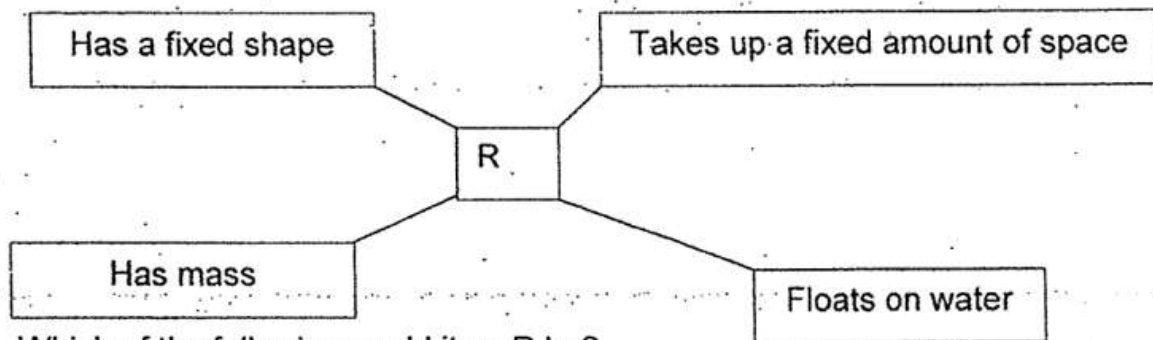

Which of the following could item R be?

- 
- A) cork
  - B) stone
  - C) needle
  - D) cooking oil

When James pumped more air into the tyre, he observed that the size of the tyre remained the same.



Which of the following best explains James' observation?

- 
- A) Air takes up space
  - B) Air can be compressed
  - C) Air has a definite volume
  - D) The tyre has a fixed shape

The diagram below shows a pair of swimming goggles.

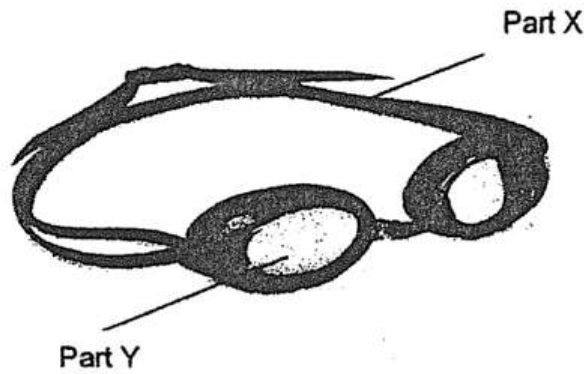

Study the properties of the four materials as shown below.

Material	Property of material		
	Flexible	Transparent	Waterproof
A	No	Yes	Yes
B	Yes	Yes	Yes
C	Yes	No	Yes
D	No	No	No

Which materials are most suitable for making Part X and Part Y?

	Material for making	
	Part X	Part Y
(1)	A	D
(2)	B	C
(3)	C	A
(4)	D	A

- A) 1
- B) 2
- C) 3
- D) 4



Wei Chong prepared four containers P, Q, R and S with the same volume of 400cm<sup>3</sup>. He added different amount of water into each container and sealed it with an air pump attached as shown in the diagram below.

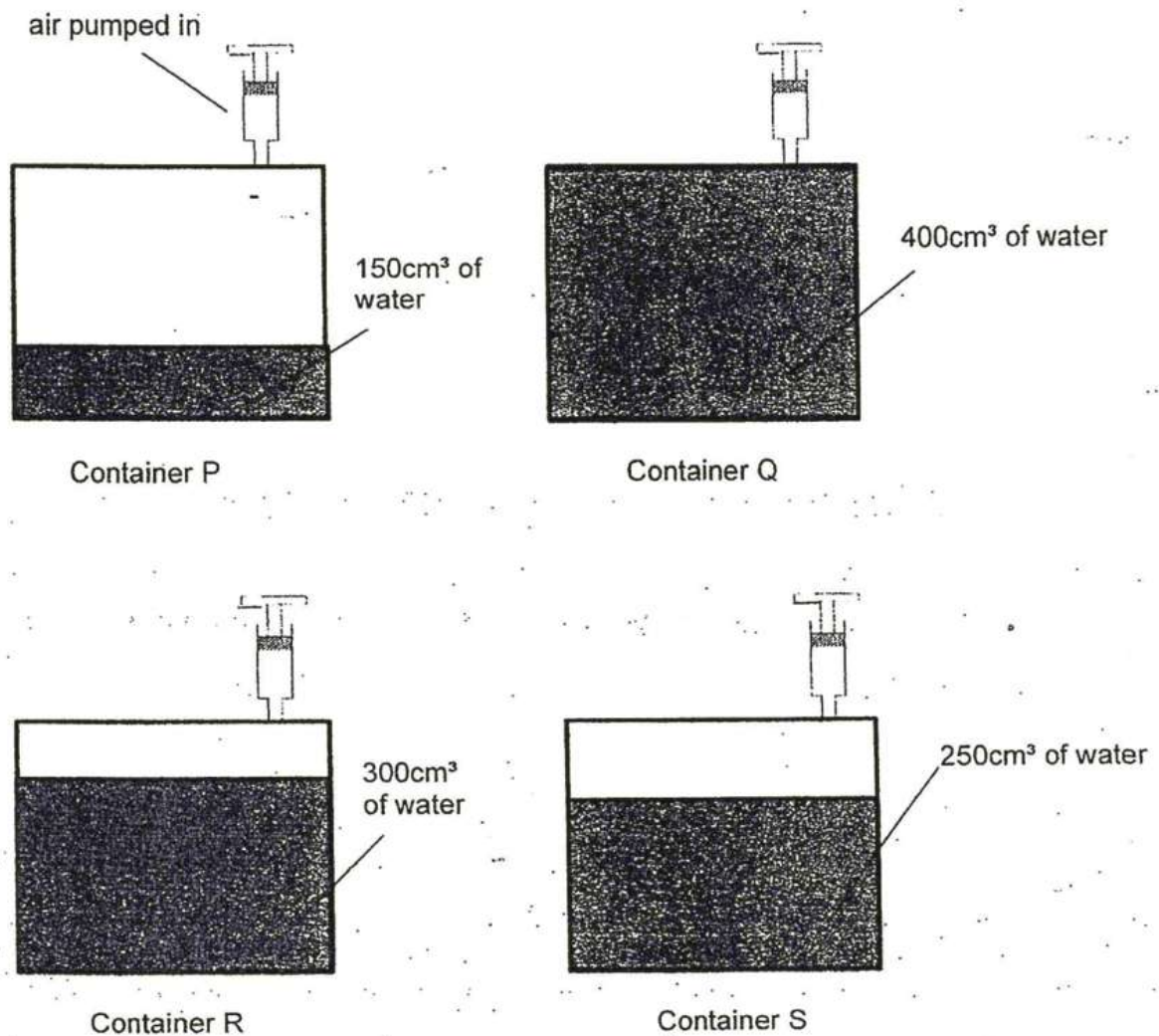

Wei Chong then pumped 300cm<sup>3</sup> of air into each container.

Air was compressed in containers \_\_\_\_\_.

- A) P and S only
- B) P, R and S only
- C) Q, R and S only
- D) P, Q and R and S

Adam used a table to describe the properties of the three states of matter, A, B and C as shown below.

Property	A	B	C
Has mass	Yes	Yes	Yes
Can be seen	Yes	No	Yes
Can be compressed	No	Yes	No
Takes up the shape of its container	Yes	Yes	No

The headings for A, B and C should be \_\_\_\_\_ respectively.

- A) Gas, Liquid and solid
- B) solid, liquid and gas
- C) solid, gas and liquid
- D) liquid, gas and solid

Rani filled a container with water as shown in Diagram 1. She then put in a metal cube into the container and observed that the water level rose as shown in Diagram 2 below.

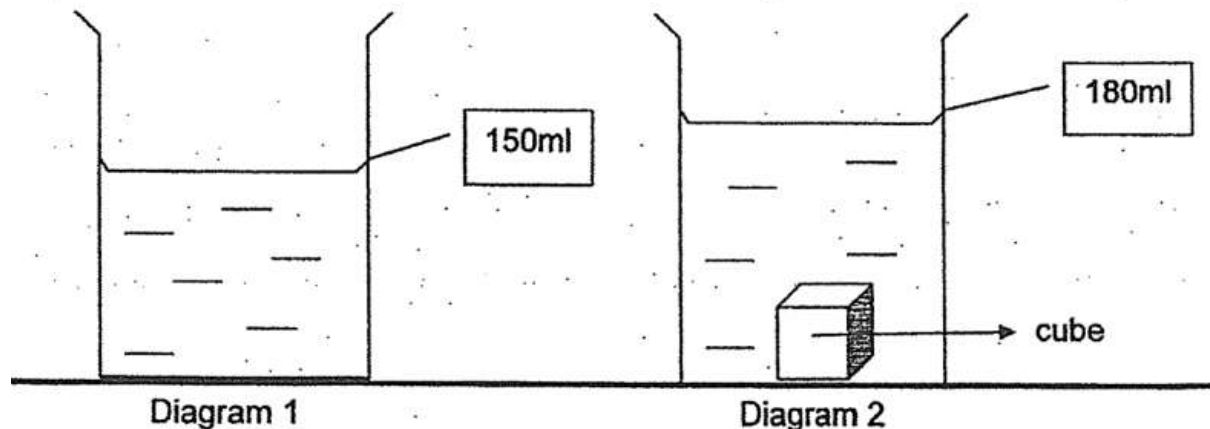

Which one of the following statements best explains Rani's observation?

- A) The cube took up space in the container
- B) The water increased in mass when the cube was put in
- C) The water increased in volume when the cube was put in
- D) The cube increased in volume when it was placed into the container

When Raja placed two identical marbles into a beaker of water, the water rose to the level as shown in Diagram 1 below.

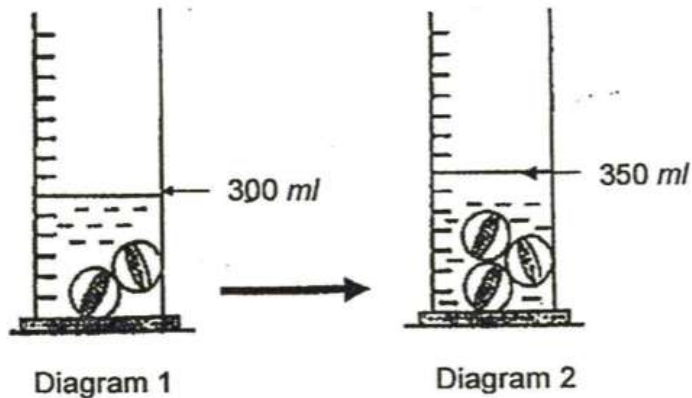

Raja then added one more marbles of the same size into the beaker of water. He observed that the water level rose as shown in Diagram 2.

What would the water level be if all the marbles were removed and what property of matter did it show?

	Water level	Property of matter
(1)	250 ml	Matter occupies space.
(2)	200 ml	Matter has mass.
(3)	200 ml	Matter occupies space.
(4)	300 ml	Matter occupies space and has no definite shape

- A) 1
- B) 2
- C) 3
- D) 4

The diagram below shows a glass jar with a capacity of  $1000 \text{ cm}^3$ .

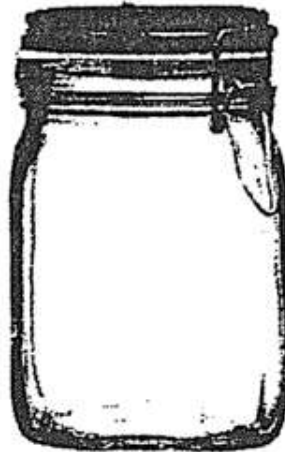

Which of the following statements are correct?

- A It can store  $500 \text{ cm}^3$  of air.
- B It can store  $1100 \text{ cm}^3$  of air.
- C It can store  $800 \text{ cm}^3$  of sand.
- D It can store  $1010 \text{ cm}^3$  of water.

- 
- A) A and C only
  - B) B and C only
  - C) A, B and C only
  - D) A, C and D only

Jaslin holds an iron sheet near a magnet hung on a retort stand. The diagram below shows her observation.

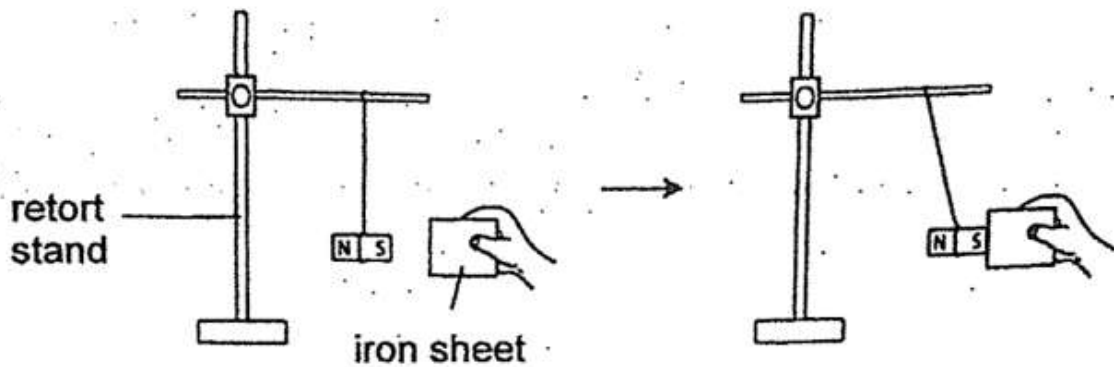

What could Jaslin conclude?

- A) A magnet is strongest at its poles
- B) A magnet can repel a magnetic object
- C) A magnet can attract a magnetic object at a distance
- D) A magnet can make a magnetic object into a temporary magnet

Wei Liang set up the following experiment as shown in Diagram 1. Four rings of the same size, A, B, C and D, are stacked through a wooden rod. Three of them are magnets.

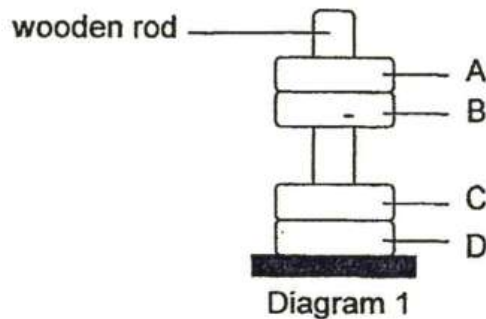

The rings are then removed and stacked in another way through the wooden rod as shown in Diagram 2 and Diagram 3.

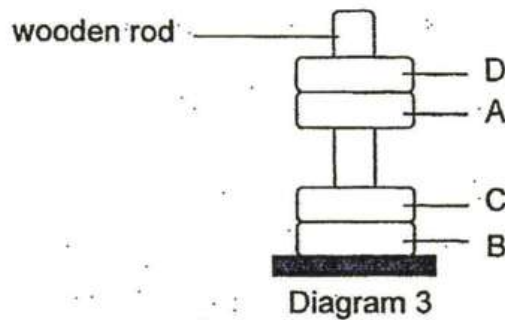
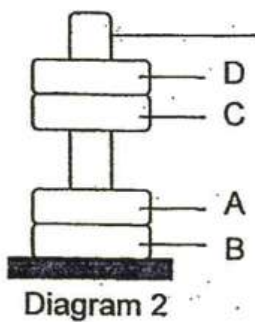

Which of the following rings are definitely magnets?

- A) B and D only
- B) A and C only
- C) A, B and C only
- D) A, C and D only

Bala dropped a piece of clay into a container filled with 1000 ml of water and recorded the water level. Next, he moulded the same piece of clay into a ball and repeated his experiment.

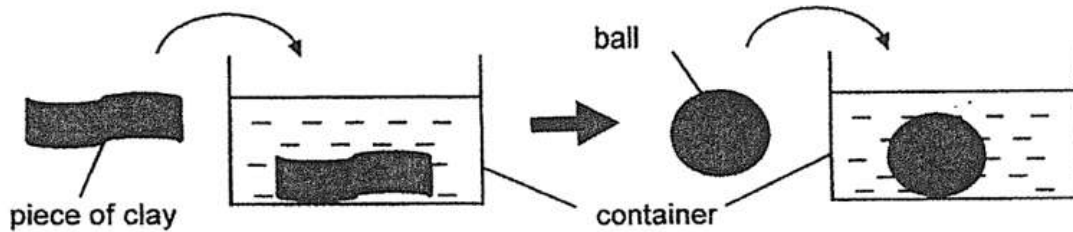

He recorded the results in the table below.

Original water level (ml)	Water level with the piece of clay (ml)	Water level with the ball of clay (ml)
1000	1200	1200

Based on Bala's results, what could he conclude about the properties of clay and water?

- A Both have mass.
- B Both occupy space.
- C Clay has a definite volume.
- D Water has a definite volume.

- A) A and C only
- B) B and D only
- C) B, C and D only
- D) A, B, C and D

The flowchart below shows the properties of materials A, B, C and D.

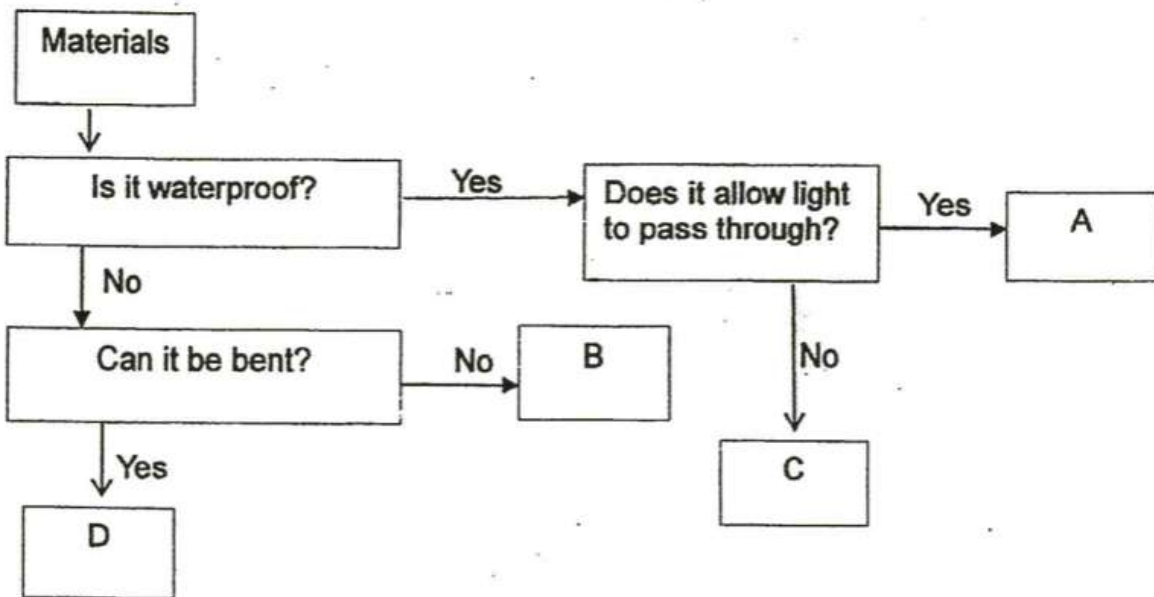

Which one of the following best represent materials A, B, C and D?

	A	B	C	D
(1)	clear glass	wood	ceramic	fabric
(2)	fabric	ceramic	wood	clear glass
(3)	ceramic	wood	clear glass	fabric
(4)	clear glass	ceramic	fabric	wood

- A) 1
- B) 2
- C) 3
- D) 4



The diagram below shows a surfboarding activity.



What properties of a surfboard help to ensure the safety of the person?

- A Strong
- B Flexible
- C Waterproof
- D Able to float

- 
- A) A and B only
  - B) B and D only
  - C) A, B and C only
  - D) A, C and D only

## Booklet B

This section is designed for extended answers that parent/ teacher will have to assign and guide child to attempt after the test has been completed.

Grading: This question type is not graded on this system and will not affect the final score as it was designed in such a way that it requires manual assistance.

In an experiment, a group of pupils took three young seedlings and placed them in a jar with damp cotton wool as shown in Diagram A.

After one week, they noted the results as shown in Diagram B.

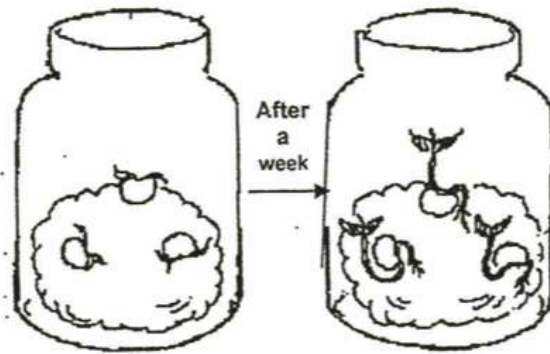
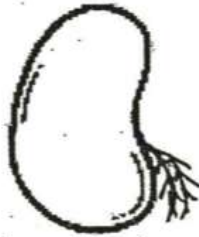

Diagram A

Diagram B

- (a) Draw and label the part which the pupils would first observe growing from the seed in diagram B above. [1]



- (b) The pupils also noticed that the seed increased in size as shown in the diagram above. Explain what had caused the seed to increase in size. [1]

- (c) State one difference between a young plant and the adult plant. [1]

Study the life cycle of the frog shown below carefully.

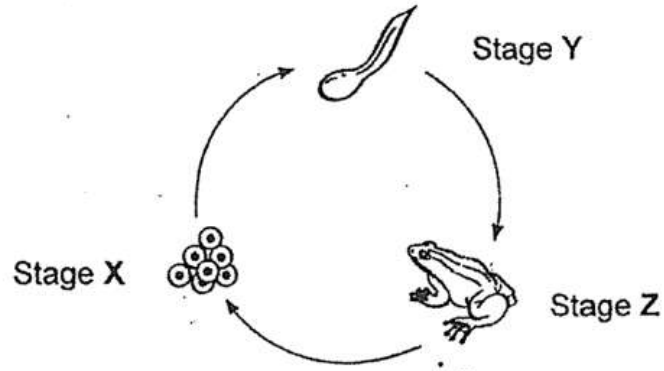

(a) Which two characteristics of living things are shown in the life cycle of the frog? [1]

(i) \_\_\_\_\_

(ii) \_\_\_\_\_

(b) What are two differences between the characteristics of the frog at stage Y and stage Z of its life cycle? [2]

Difference 1: \_\_\_\_\_  
 \_\_\_\_\_  
 \_\_\_\_\_

Difference 2: \_\_\_\_\_  
 \_\_\_\_\_

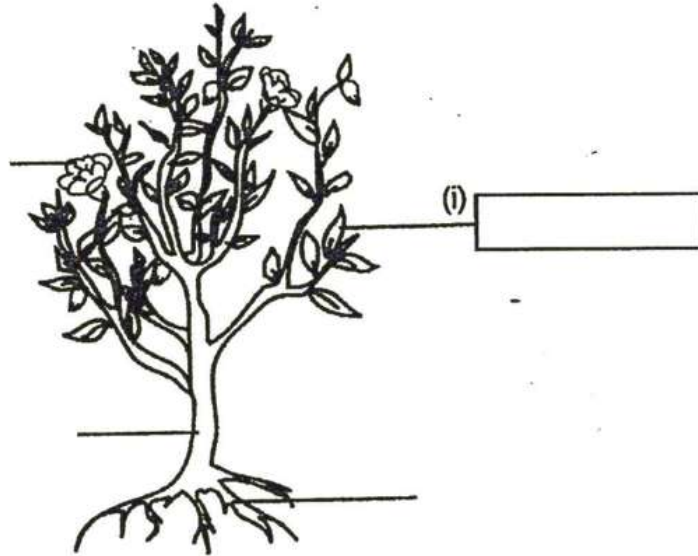

(a) Label the parts of the plant in the boxes provided.

[2]

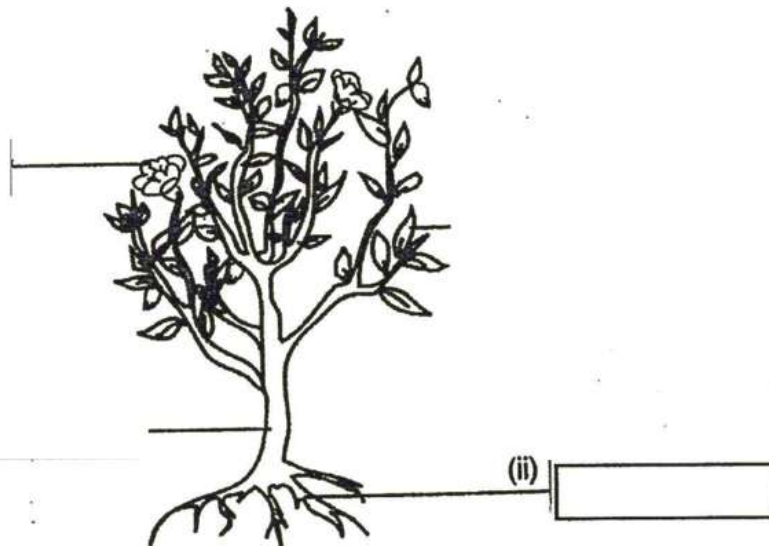

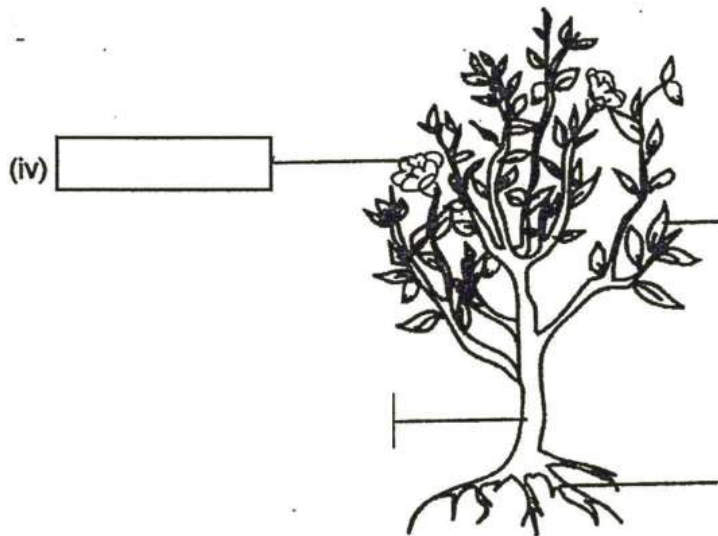
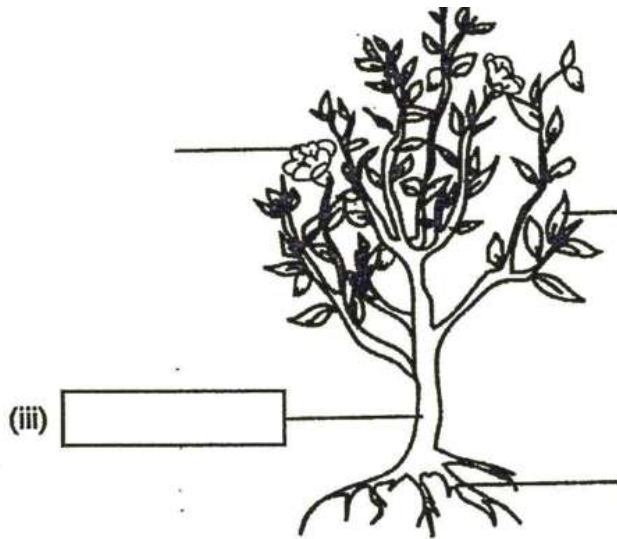

(b) What are the two functions of Part (i) of the plant? [1]

---

---

---

(c) How does an increase in the amount of Part (ii) of the plant affect the amount of water absorbed by the plant? [1]

---

---

---

2 The diagram below shows a human body system.



(a) What is the function of this system? [1]

---

---

Study another human body system shown below.

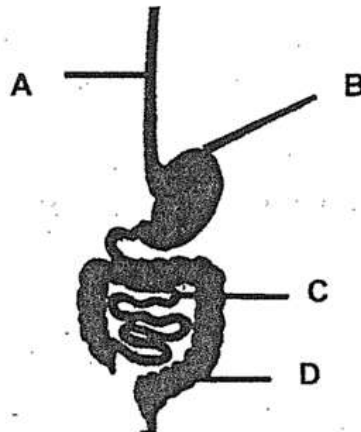

(b) Which organs labelled above help in the digestion of food? Explain why. [1]

---

---

(c) What is the function of organ D? [1]

---

---

The classification chart below shows the characteristics of three animals, P, Q and R.

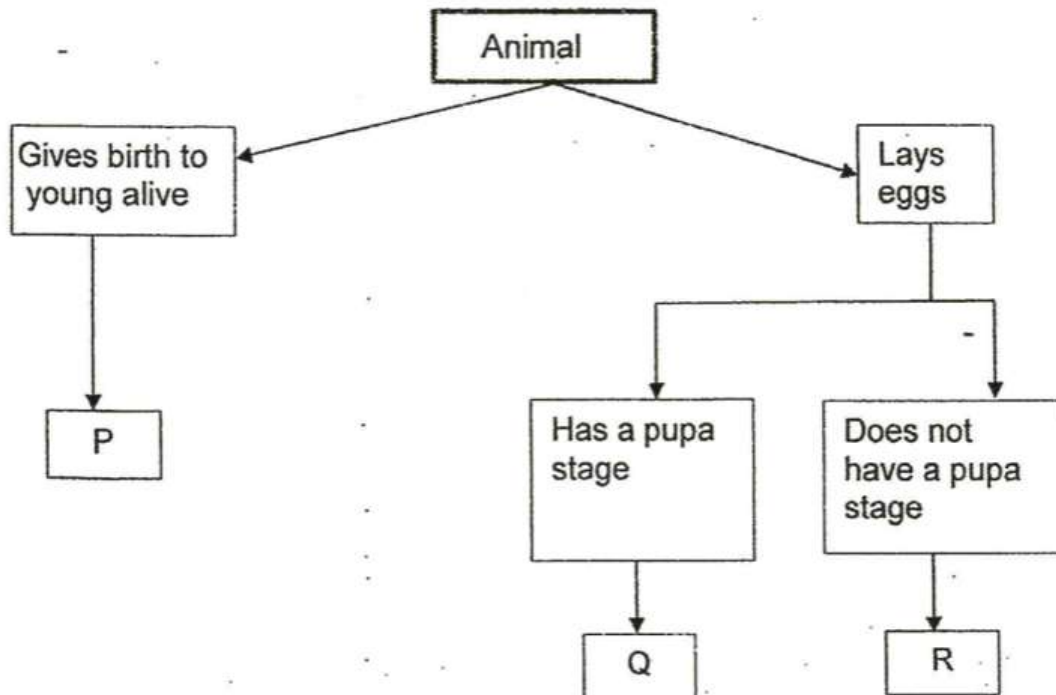

Which one of the animals is likely to have a young that looks like its parents?

[1]

- 
- A) P
  - B) Q
  - C) R



Draw the life cycle of an insect that has the same characteristics as animal R.

[1]

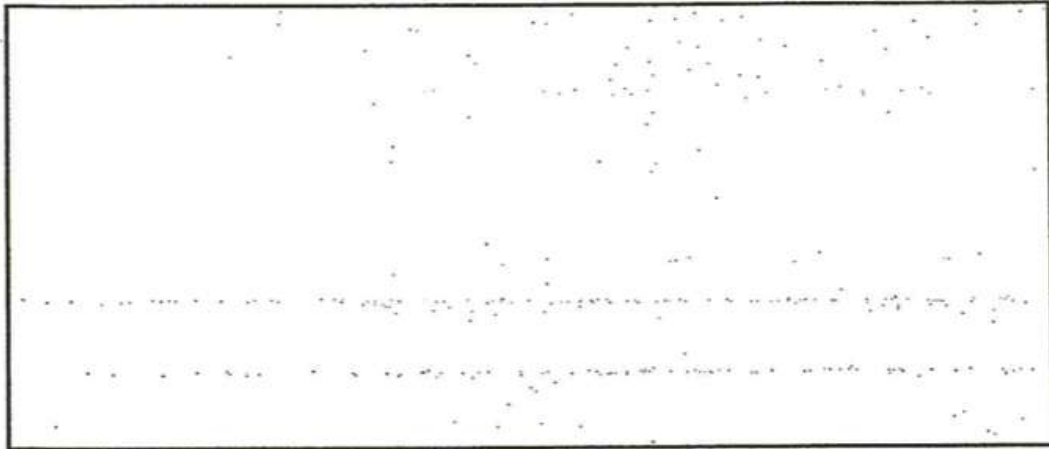

Please type "done" to proceed to the next question

---

The life cycles of a mealworm beetle and a grasshopper are shown below.

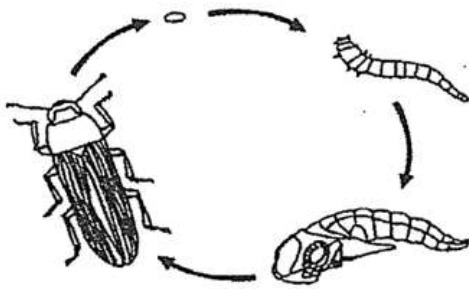

Mealworm beetle

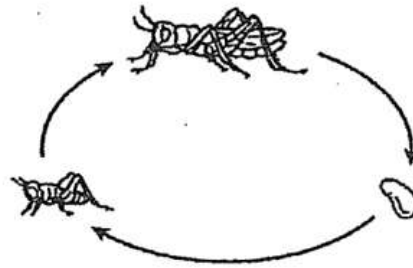

Grasshopper

- (a) Based on the diagrams above, write down two differences between the life cycles. [2]

Difference 1: \_\_\_\_\_

\_\_\_\_\_

Difference 2: \_\_\_\_\_

\_\_\_\_\_

- (b) Why is it important for the grasshopper and mealworm beetle to lay many eggs at one time? [1]

\_\_\_\_\_

Lucas conducted an experiment using a magnet. He placed one paperclip at a time on different positions, A, B, C, D and E, on the magnet until no more paperclips were attracted by the magnet.

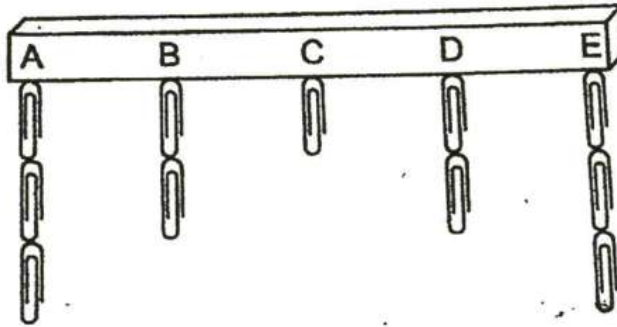

He then recorded his results in the table shown below.

Position	A	B	C	D	E
Number of paper clips	3	2	1	2	3

Lucas then attached the magnet above on the wall and bought some strong magnetic hooks to hang some items.



- (a) Based on the results above, which two positions, A, B, C, D or E, would he choose to hang a 50g weight? [1]
- (i) Positions: \_\_\_\_\_ and \_\_\_\_\_

- A) A
- B) B
- C) C
- D) D
- E) E

Explain your answer in (a)

Sue carried out an experiment using an electromagnet as shown below.

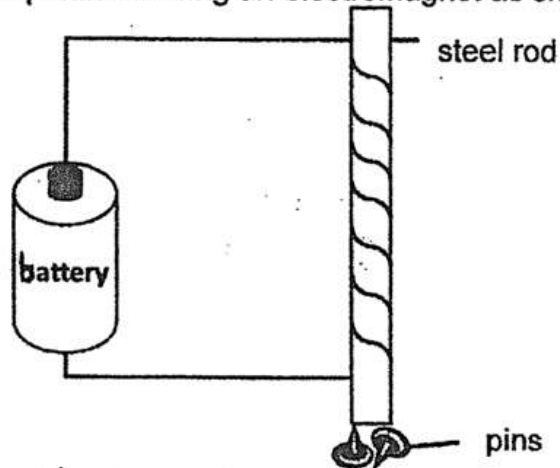

She changed the number of turns of the wire on the rod and the results were recorded in the table below.

No. of turns of wire	No. of pins attracted
12	2
18	4
25	7
30	9

(a) What was Sue trying to find out in this experiment? [1]

---

---

(b) How could Sue ensure that the results of her experiment were more reliable? [1]

---

(c) What could Sue do to attract more pins besides increasing the number of turns of wire on the steel rod? [1]

---

The container below contains  $400\text{cm}^3$  of air. David tried to push the plunger of the syringe and he observed that only a little water could enter into the container.

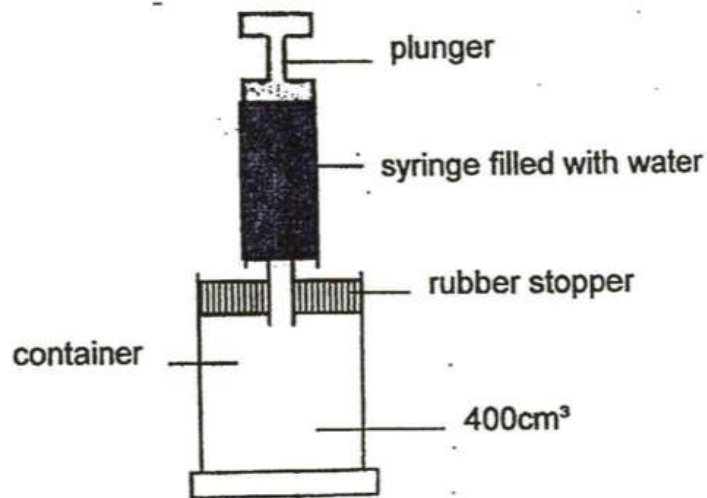

- (a) Explain why only a little water could enter into the container. [1]

---

---

- (b) What should David do in order to allow more water in the syringe to enter the container? Give a reason for your answer. [1]

---

Sheila added  $200 \text{ cm}^3$  of water into Container A. She then put  $200 \text{ cm}^3$  of pebbles into Container B with a capacity of  $500 \text{ cm}^3$ . Next, she poured the water from Container A into Container B.

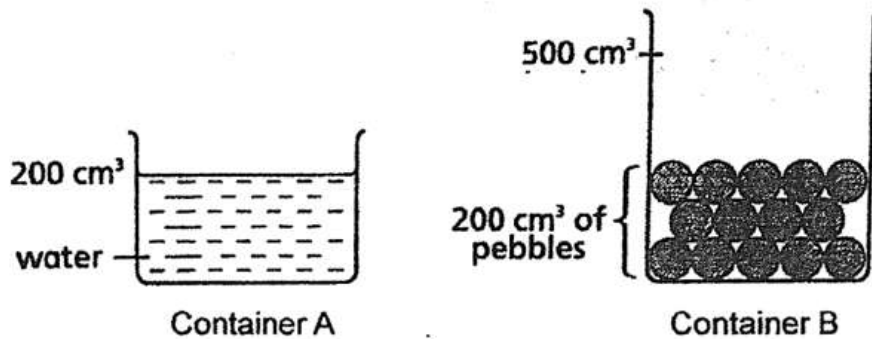

- i) What would be the total volume of water and pebbles in Container B? [1]  
Put a tick ( $\checkmark$ ) in the correct box below.

- A)  $200 \text{ cm}^3$   
 B)  $350 \text{ cm}^3$   
 C)  $400 \text{ cm}^3$

- (b) Explain your answer in (a). [1]

---

---

- (c) What property of matter could Sheila observe from this experiment? [1]

---

Sheila explored further by using two cubes of the same size but made of different types of metals as shown in the diagram below.

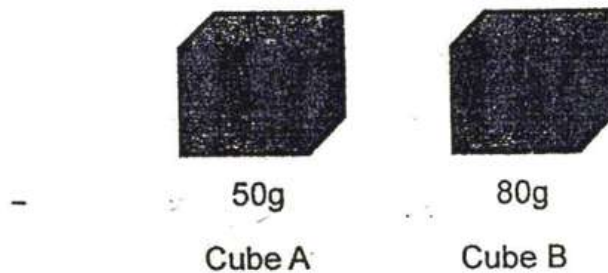

She tied a string to each of the cubes. When she lowered Cube A gently into a measuring cylinder containing  $30\text{cm}^3$  of water, the water level rose up to  $45\text{cm}^3$ . She removed Cube A and lowered Cube B into the same measuring cylinder.

- (d) What would be the new water level? State the common property of the cubes. [1]

---

---

- (e) What could Sheila conclude from this experiment? [1]

---

Four thin sheets of similar size materials A, B, C and D were used for this experiment. The table below shows the mass of these sheets before and after they were put into four beakers, each containing an equal amount of water.

Material	Before	After 20 minutes
A	8 g	8 g
B	10 g	18 g
C	16 g	20 g
D	13 g	15 g

- (a) Based on the results given, explain which material you would use to make a pair of gloves. [1]

---

---

Meena wears a pair of gloves made from the material chosen in (a) to keep her hands dry when doing household chores as shown below.



- (b) Based on the picture, list one important property of this material and explain why. [1]

---



Mary decided to perform a magic trick for her friends. She prepared the set-up below. An iron nail and a steel paper clip were tied to a string of length 25cm and was attached to the base of the box. Without touching the steel paper clip and the iron nail, Mary was able to make them "float" in the box.

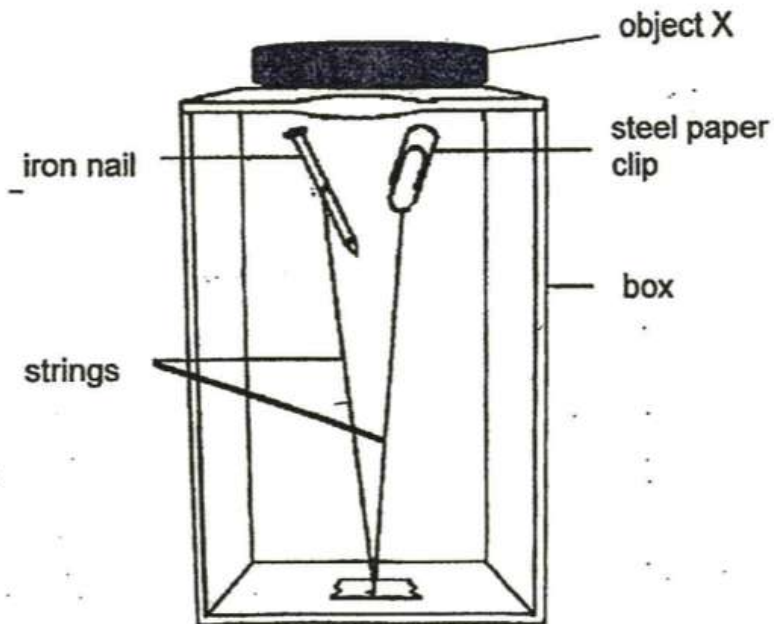

- (a) What could object X be? Explain your answer. [1]

---

---

- (b) However, Mary was unable to perform her magic trick when she cut her strings to a shorter length. Give a reason for your answer. [1]

---